

PROFESSIONAL WEATHER STATION

Model no.: WH5300SE

Operation Manual

About this manual

Thank you and congratulations on selecting this professional weather station! We are positive you will enjoy the benefits of accurate weather readings and the precise radio controlled time information that our instruments offer.

This manual will guide you step-by-step through setting up your device. Use this manual to become familiar with your professional weather station, and save it for future reference.

Safety

- Do not expose the main unit to rain or moisture
- Use only recommended batteries
- Remove the batteries if the weather station is not to be used for a long time. Old batteries can begin to leak and damage the product.
- Remember to insert the batteries according to the markings in the battery compartment. The wrong polarity (+/-) can damage the weather station.
- Damage that has occurred by careless handling is not covered by the guarantee

Production Description.

- Display of indoor and outdoor temperature, wind speed, wind direction, humidity, rainfall amounts, time and date
- Alarm function for certain weather conditions as well as records of all minimum and maximum values along with time and date of their recordings
- Radio control time and date
- Save the data when batteries is changed
- Operates on 5x LR6/AA alkaline batteries (not included)

Contents

- Main unit
- Transmitter(thermo-hygro sensor)
- Rain collector
- Sensor for wind speed and wind direction
- Sensor bracket
- Adjustable hoops

- ① Transmitter (thermo-hygro sensor) inside a radiation shield
- ② Rain collector
- ③ Sensor for wind speed
- ④ Sensor for wind direction
- ⑤ Sensor bracket
- ⑥ Bubble level

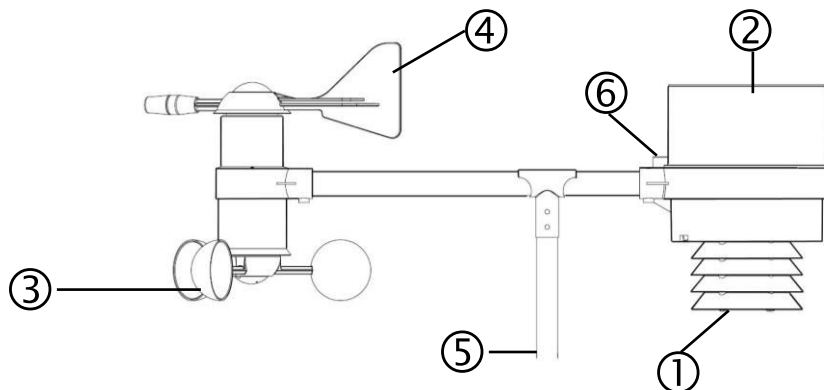

LCD Display

The following illustration shows the full segments of the LCD for description purpose only and will not appear like this during normal operation and use.

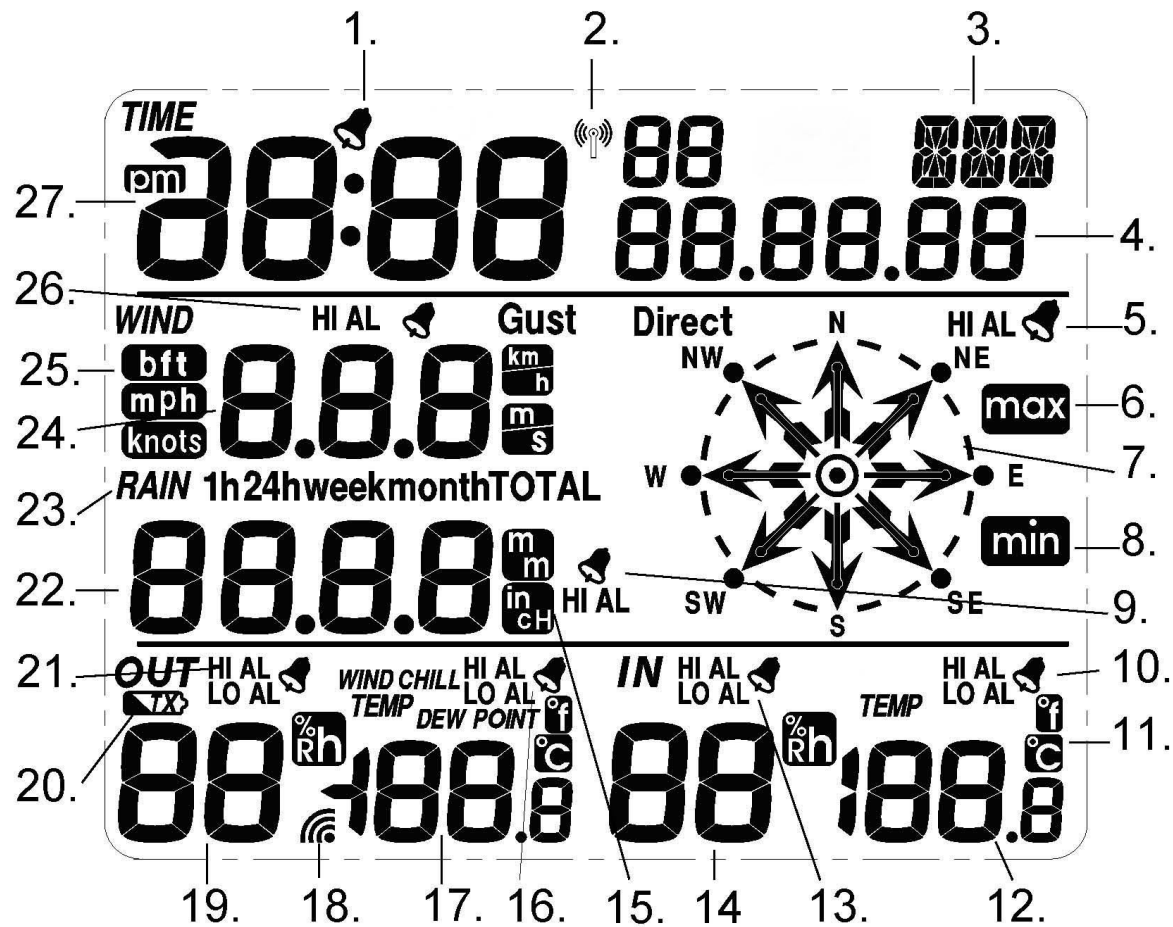

- | | |
|---|---|
| 1. Time alarm on icon | 15. Rainfall unit |
| 2. RCC tower icon for time reception | 16. Outdoor temperature high alarm and low alarm |
| 3. Date of the week/time zone | 17. Outdoor temperature |
| 4. Date | 18. Outdoor reception signal |
| 5. Wind direction alarm | 19. Outdoor Humidity |
| 6. General Max record | 20. Outdoor transmitter low battery indicator |
| 7. Wind direction | 21. Outdoor humidity high alarm and low alarm |
| 8. General Min. record | 22. Rainfall |
| 9. Rainfall high alarm | 23. Rainfall 1h,24h, week, month or total display |
| 10. Indoor temperature high alarm and low alarm | 24. Wind speed |
| 11. Temperature unit | 25. Wind speed unit |
| 12. Indoor temperature | 26. Wind speed high alarm |
| 13. Indoor humidity high alarm and low alarm | 27. Time |
| 14. Indoor humidity | |

Note: The presence of the "Alarm-On icon" in the section means that the particular alarm has been enabled.

Set up Guide

Inserting the batteries

Transmitter/outdoor unit

1. Turn the screwdriver counter clockwise to loosen the screw, turn aside the sheet metal (figure 1)
2. Pull out the battery compartment (figure 2)
3. Insert 2xAA alkaline battery in the battery compartment. (figure 3) Push the battery compartment into the rain collector unit.

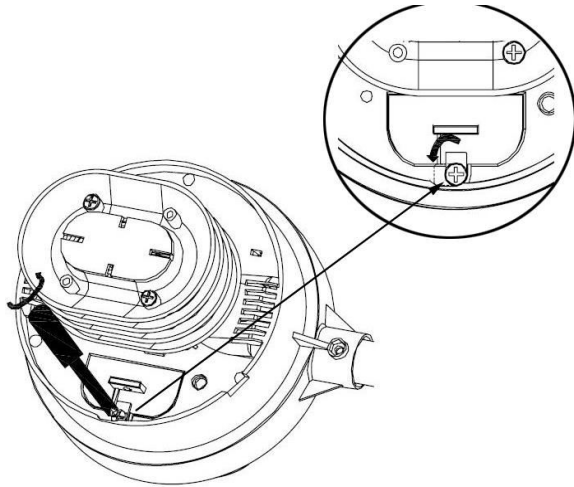

Figure 1

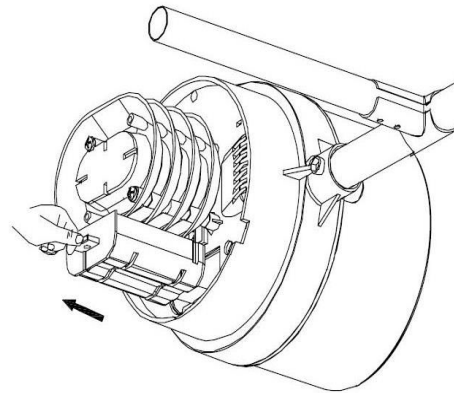

Figure 2

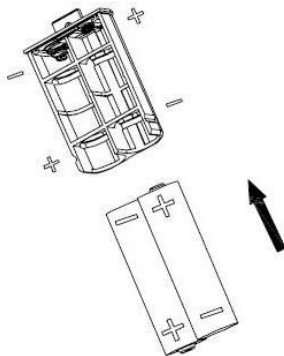

Figure 3

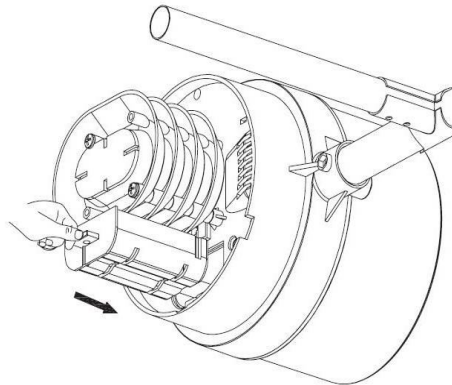

Figure 4

Insert 2xLR6 (AA size) batteries into the transmitter, the LED located in the back of rain collector will be turned on for 4 seconds, then it will be off and start to work normally. The transmitter will make a data transmission and then start radio controlled time reception routine. If time signal can be detected correctly, the LED will start to flash 5 times, and then the LED will be on for 20s, indicating time signal has been found correctly. When time signal is bad and reception is not possible, the transmitter will terminate radio controlled time reception within one minute and resume normal mode. When there is a data transmission happened, the LED will be on for 20ms. During radio controlled time reception period, there is no transmission and normal transmission will only resume after time reception routine is complete. The longest time for radio controlled time reception is 5 minutes.

Receiver /Indoor unit

After inserting the batteries into the Weather Station, all LCD segments will be turned on for a few seconds, all possible display segments are turned on for checking.

After this, the weather station will make initial measurement and start to register the transmitter (the radio reception icon will be turned on). Do not press any key before outdoor sensor data received, otherwise the outdoor sensor learning mode will be terminated. When outdoor transmitter has been registered, the base station will automatically switch to the normal display mode from which all further settings can be performed by the user.

If no RCC signal is detected in the initial setup, the transmitter will try once every two hours to get an RCC signal until a signal is received. Once the transmitter receives the RCC signal it will transmit the signal to the monitor. On the monitor the RCC tower icon will be displayed, if the monitor doesn't receive the RCC signal or loses the signal continuously for 12 hours the RCC icon will not be display.

Note for RCC signal:

The best condition for reception is at night, between midnight and 6:00am – when there is less atmospheric interference.

Note:

If a battery change on the transmitter side happened, the receiver will be resynchronized to the transmitter again within the next 3 hours. If you want to shorten the receiving data time, the base station has to re-install the battery so that it can have the new security code learnt right way, but the previous weather data and alarm value settings in receiver will be lost.

Note:

Commonly the radio communication between receiver and transmitter in the open field can reach a distance of up to 330 feet providing that there are no interfering obstacles such as buildings, trees, vehicles, high voltage lines, etc.

Radio interferences such as PC screens, radios or TV sets can, in bad cases, entirely cut off radio communication. Please take this into consideration when choosing standing or mounting locations.

Mounting

Before placing and installing all components of the weather station at there final destination, please set up the weather station with all parts being nearby for testing the correct function. If e.g. there appear to be problems with the 868 MHz radio transmission, they can mostly be overcome by moving the mounting locations.

Transmitter (thermo-hygro sensor), rain collector, wind direction sensor have been mounted onto the mast. You just need to assemble the wind cups attached.

Attaching the Wind Cups

1. Push the wind cups onto the anemometer's stainless steel shaft.
2. Use the Allen wrench provided to tighten the set screw on the side of the wind cups.
3. Spin the wind cups. If the wind cups spin freely, the anemometer is ready and can be installation.

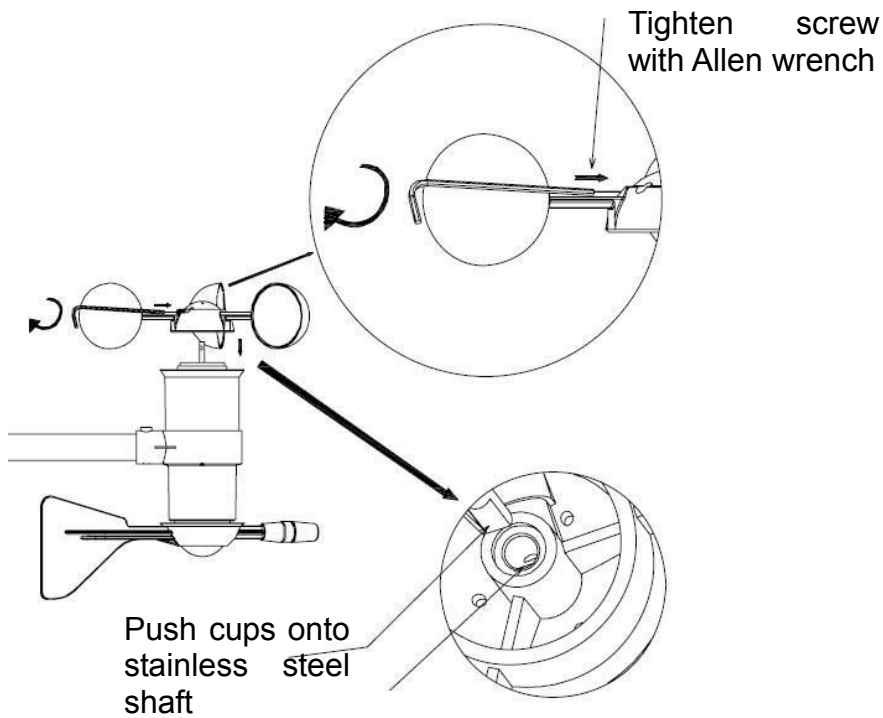

Figure5

Note

On the edge of wind direction sensor, there are four alphabet letter of “N”, “E”, “S” and “W” representing for the direction of North, East, South and West. Wind direction sensor has to be adjusted so that the directions on the sensor are matching with your real location. Permanent wind direction error will be introduced when the wind direction sensor is not positioned correctly during installation.

Level the sensors

Use the bubble level on the rain sensor as a guide to verify that sensors are level.

Program Mode

The base station has five keys for easy operation: **SET** key, **+** key, **HISTORY** key, **ALARM** key, **MIN/MAX** key

Note:

When setting certain units in the manual setting mode, hold the **+** or **MIN/MAX** key for 2s will increase/decrease digits in greater steps.

The setting procedure can be exited at any time by either pressing the **HISTORY** key or waiting for the 30-second time-out to take effect.

Quick Display Mode

- While in normal display, Press the **SET** key to enter the Quick Display Mode as follow:

- Wind speed / Gust speed (press the **+** key or **MIN/MAX** key shifts the display between the wind speed and gust speed)

- 1 hour / 24 hour / week / month / total rainfall quantity (press the + key or **MIN/MAX** key shifts the display between the selectable rainfall quantities), while display the rainfall total quantity, pressing the **SET** key for 2 seconds will reset the rainfall total value to zero.
- Outdoor Temperature / Wind chill / Dew point (press the + key or **MIN/MAX** key shifts the display between outdoor temperature, wind chill and dew point)

Press the **SET** key to accept the change and advance to the next display mode. Continue to press the **SET** key to toggle through the display mode until return to the normal Mode

Setting Mode

- Press the **SET** key for 2 second while in normal mode to enter the Setting mode, LCD contrast digits will start flashing. You can skip over any setting by press the **SET** key. Press + key or **MIN/MAX** key to select the units or scrolls the value. Holding the + key or **MIN/MAX** key for 2 second will increase/decrease digits in great steps. To exit the Setting mode at any time, press the **HISTORY** key.

- Time Zone Setting (-12→12)
Note: At Europe, 0 for GMT+1 time zone, 1 for GMT+2 time zone, -1 for GMT time zone.
- 12/24h time display select.
- Manual time setting (hours/minutes)
- Select DD-MM or MM-DD format.
- Calendar setting(year /month/ date)
- Wind speed and gust display units in km/h, m/s, bft, mph, knots
- Wind direction
- Rainfall display units in mm or inch
- Temperature display unit degree Celsius or Fahrenheit

Calibration Mode

- Press the **HISTORY** key for 8 second while in normal mode to enter the Calibration Mode, and the wind factor digits will start flashing. You can skip over any setting by press the **SET** key. Press + key or **MIN/MAX** key to select the units or scrolls the value. Holding the + key or **MIN/MAX** key for 2 second will increase/decrease digits in great steps. To exit the Calibration mode at any time, press the **HISTORY** key.

- Wind Speed Calibration (default is 1.0, adjustment rang 0.75 to 1.25)
- Rainfall data Calibration (default is 1.0, adjustment rang 0.75 to 1.25)
- History rainfall Calibration
- Outdoor humidity Calibration
- Outdoor temperature Calibration
- Indoor humidity Calibration
- Indoor temperature Calibration

Wind Speed Calibration

Wind speed is the most sensitive to installation constraints. The weather station should not be located close to buildings, trees or other obstructions.

Many installations are not perfect and installing the weather station on a roof can be difficult. Thus, you can calibrate for this error with a wind speed multiplier.

In addition to the installation challenges, wind cup bearings (moving parts) wear over time.

Without a calibrated source, wind speed can be difficult to measure. We recommend using a calibrated wind meter and a constant speed, high speed fan.

Temperature Calibration

Temperature errors can occur when a sensor is placed too close to a heat source (such as a building structure, the ground and when placed in direct sunlight without proper shielding in hot weather environments).

To calibrate temperature, we recommend a mercury or red spirit (fluid) thermometer. Bi-metal (dial) and other digital thermometers are not a good source and have their own margin of error. Using a local weather station in your area is also a poor source due to changes in location, timing (airport weather stations are only updated once per hour) and possible calibration errors (many official weather stations are not properly installed and calibrated).

Place the sensor in a shaded, controlled environment next to the fluid thermometer, and allow the sensor to stabilize for 48 hours. Compare this temperature to the fluid thermometer and adjust the console to match the fluid thermometer.

Humidity Calibration

Humidity is a difficult parameter to measure accurately and drifts over time. Humidity errors can occur when placed too close to the ground, near grass or other sources of humidity.

The hygrometer sensor utilizes a capacitor, which varies as a function of humidity. Due to manufacturing tolerances, the accuracy of the sensor is $\pm 5\%$. To improve on this accuracy, the indoor and outdoor humidity readings can be adjusted or calibrated from the display console.

To calibrate humidity, you will need an accurate source, such as a sling psychrometer or Humidipaks One Step Calibration kit.

Rainfall calibration

The Rain Collector is calibrated at the factory so the bucket tips (and records rainfall) for each 0.01" (or 0.3 mm) of rain. To calibrate rainfall, we recommend a tube type rain gauge. Use a rain gauge with an aperture of at least 4 inches. Any smaller and the readings obtained may not be accurate. Place the tube type rain gauge directly next to the rain collector. Compare the totals on three storms. Based on this, develop an average for how far off the readings are.

Do not compare rainfall readings to reading obtained from television, radio, newspapers, or neighbors' readings. Such readings are not located in your specific environment and therefore are not an accurate measurement of the weather readings taking place in your surroundings. The rain collector is carefully tested at the factory to conform to the specifications listed in the back of this manual.

The history rainfall calibration factor is applied to the running total, not individual tips. All of the rainfall figures are calculated from the total number of tips recorded by the station since it was reset. The total is multiplied by 0.3 to get a total in mm. This is then converted to inches if necessary by multiplying by 0.0393700787. The calibration multiplier is then applied to this, and this is the figure that remembers and compares each time a new total is read from the station.

History Modes

- While in Normal Mode, press the **HISTORY** key to enter the History Mode.
- In the history mode, press **SET** key will trigger the history clear procedure: the word of "CLEAR" will be flashing, hold the **SET** key for 2 seconds will clear all the history records.

- In the history mode, press the **MIN/MAX** key to select the record over the past 24hours at increments of -3 hours, -6 hours, -9 hours, -12 hours, -15 hours, -18 hours, -21 hours, -24 hours.

Press the **HISTORY** key or key idle 30 second to return to Normal Mode

Alarm Modes

- While in Normal Mode press the **ALARM** key to enter the High Alarm Mode, Press the **ALARM** key again to enter Low Alarm mode, press the **ALARM** key the third time to return the Normal Mode.

Remark: after the initial pressing of **ALARM** key, the display will be refreshed to show current high, low alarm values. Normal alarm value will be displayed only for those already activated, all other not activated values will be displayed with “- -“or “- -“instead.

-In the High Alarm Mode press the **SET** key to select the following alarm modes:

1. Time alarm
2. Wind speed high alarm (0-50m/s)
3. Gust speed high alarm (0-50m/s)
4. Wind direction alarm
5. 1Hour rain high alarm (0-999.9mm)
6. 24 hour rain high alarm (0-999.9mm)
7. Outdoor humidity high alarm (1%-99%)
8. Outdoor temperature high alarm (-40°C--60°C)
9. Wind chill high alarm (-40°C--60°C)
10. Dew point high alarm (-40°C--60°C)
11. Indoor humidity high alarm (1%-99%)
12. Indoor temperature high alarm (-9.9°C--60°C)

-In the Low Alarm Mode press the **SET** key to select the following alarm modes:

1. Time alarm
2. Outdoor humidity low alarm (1%-99%)
3. Outdoor temperature low alarm (-40°C--60°C)
4. Wind chill low alarm (-40°C--60°C)
5. Dew point low alarm (-40°C--60°C)
6. Indoor humidity low alarm (1%-99%)
7. Indoor temperature low alarm (-9.9°C--60°C)

- In the alarm modes, press **+** key or **MIN/MAX** key to change or scroll the alarm value.

Hold the **+** key or **MIN/MAX** key for 2 second will increase/decrease digits in great steps. Press the **ALARM** key to select the alarm on or off (if alarm is enabled, the speaker icon on the LCD will be turned on indicating the alarm function has been enabled).

- Press the **SET** key to toggle through each alarm mode until it returns to the normal display mode.

-Press **HISTORY** key or key idle 30 second at any time, the alarm mode will return to Normal Mode

Canceling the Temperature Alarm While Sounding

a. When a set weather alarm condition has been triggered, that particular alarm will sound for 120 second and flash until the weather condition doesn't meet the user set level. Press any key to mute the alarm. When weather alarm condition was activated again within 3 hours, alarm will not sound but will continue to flash until weather conditions have become more steady. This feature is useful to avoid repeated triggering for the same alarm value.

b. The alarm will reactivate automatically once the value has fallen below the set value.

Min/Max Mode

- While in Normal Mode, press the **MIN/MAX** key to enter the maximum mode
- Press **MIN/MAX** key again to enter the minimum mode
- Press **MIN/MAX** key again to return the Normal Mode.
- In the maximum reading Mode, press the **+** key to display the following maximum values together with the time and date stamp when these values were recorded, if hold the **SET** key for 3s in the following individual maximum value will be reset to current reading together with the current time and date.
 1. Wind speed maximum
 2. Gust speed maximum
 3. 1Hour rain maximum
 4. 24 hour rain maximum
 5. Week rainfall maximum
 6. Month rainfall maximum
 7. Outdoor humidity maximum
 8. Outdoor temperature maximum
 9. Wind chill temperature maximum
 10. Dew point temperature maximum
 11. Indoor humidity maximum
 12. Indoor temperature maximum
- In the minimum reading Mode, press the **+** key to display the following minimum values together with the time and date at which these values were recorded, if hold the **SET** key for 3s in the following individual minimum value will be reset to current reading together with the current time and date.
 1. Outdoor humidity minimum
 2. Outdoor temperature minimum
 3. Wind chill temperature minimum
 4. Dew point temperature minimum
 5. Indoor humidity minimum
 6. Indoor temperature minimum
- Press the **HISTORY** key or key idle 30 second, the **MIN/MAX** mode will return to Normal Mode

Reset To Factory Default Settings

While in normal display, press and hold the **+** key for 20s to reset all settings to the manufacturer default setting

Specifications

Outdoor data

Transmission distance in open field :	100m(300 feet)
Frequency :	868 MHz
Temperature range :	-40°C--65°C (-40°F to +149°F)
Accuracy :	+ / - 1 °C
Resolution :	0.1°C
Measuring range rel. humidity :	1%~99%
Accuracy :	+/- 5%
Rain volume display :	0 – 9999mm (show --- if outside range)
Accuracy :	+ / - 10%
Resolution :	0.3mm (if rain volume < 1000mm)

1mm (if rain volume > 1000mm)

Wind speed : 0-180km/h (0~110mph) (show --- if outside range)
Accuracy: +/- 1m/s (wind speed < 10m/s)
+/-10% (wind speed > 10m/s)

Measuring interval thermo-hygro sensor: 48 sec

Indoor data

Measuring interval temperature/humidity : 30 sec
Indoor temperature range : -9.9°C--60°C (14°F to + 140°F) (show --- if outside range)
Resolution : 0.1°C

Measuring range rel. humidity : 1%~99%
Resolution : 1%

Alarm duration : 120 sec

Power consumption

Base station : 3XAA 1.5V LR6 Alkaline batteries
Remote sensor : 2xAA 1.5V LR6 Alkaline batteries
Battery life : Minimum 12 months for base station
Minimum 24 months for thermo-hygro sensor

Remark:

Where outdoor temperature is lower than -20°C, make sure proper type of batteries to be used to assure that the device can get enough power to maintain its function properly. Normal alkaline batteries is not allow to be used since when outdoor temperature is lower than -20 °C, the battery's discharging capability is greatly reduced.

When out of the temperature range of 10~35°C, transmitter low battery indicator maybe show up abnormally even you change new batteries because the low voltage test point will rise along with the temperature drop under 10°C. In this case, you don't need to change the transmitter batteries. The low battery indicator will work normal when the outdoor temperature rise to 10~35°C.



Please help in the preservation of the environment and return used batteries to an authorized depot.

All rights reserved. This handbook must not be reproduced in any form, even in excerpts, or duplicated or processed using electronic, mechanical or chemical procedures without written permission of the publisher.

This handbook may contain mistakes and printing errors. The information in this handbook is regularly checked and corrections made in the next issue. We accept no liability for technical mistakes or printing errors, or their consequences.
All trademarks and patents are acknowledged.

Appendix

How to replace the sensor

Replace Rain collector and thermo-hygro sensor

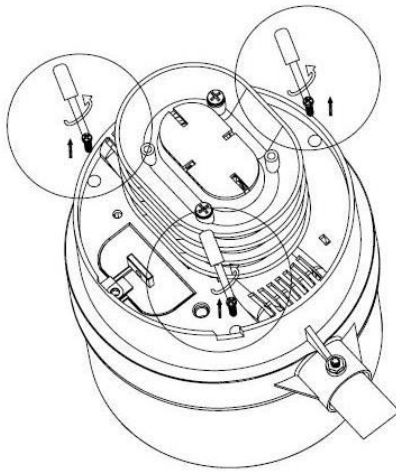

①

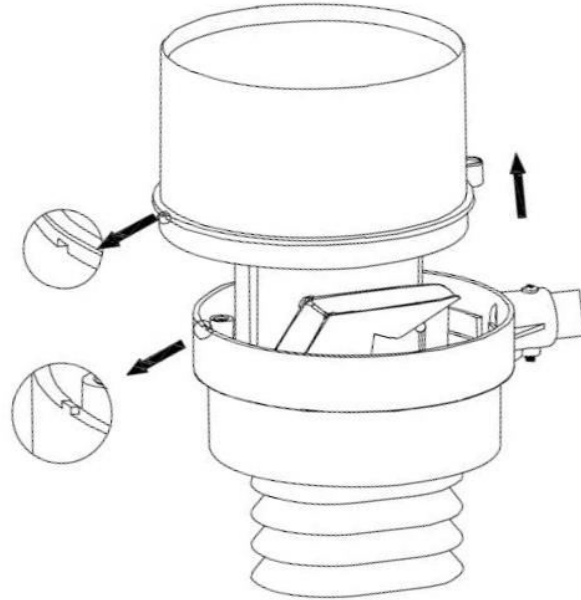

②

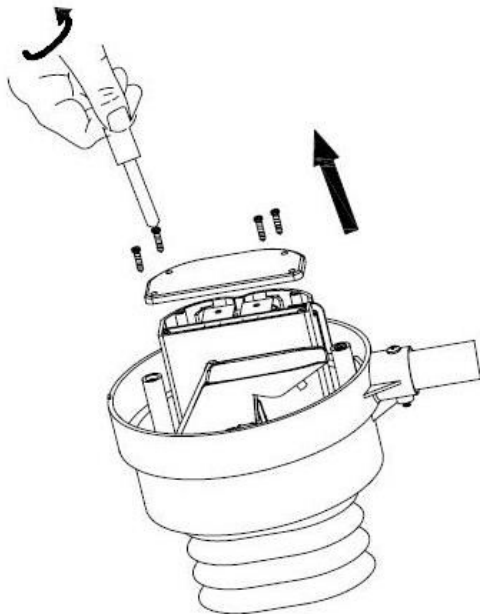

③

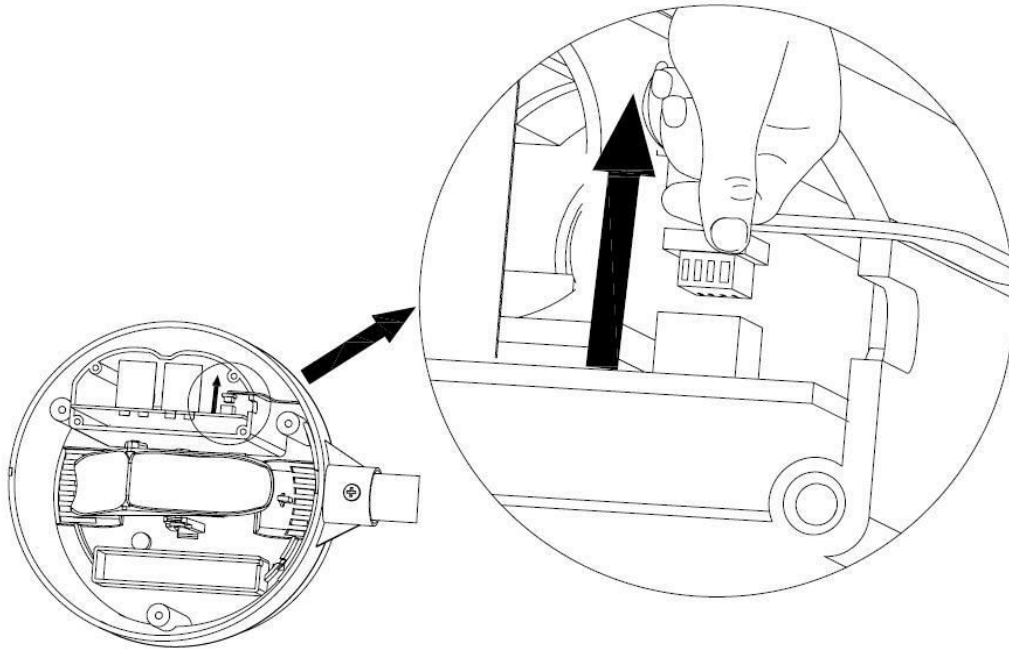

④

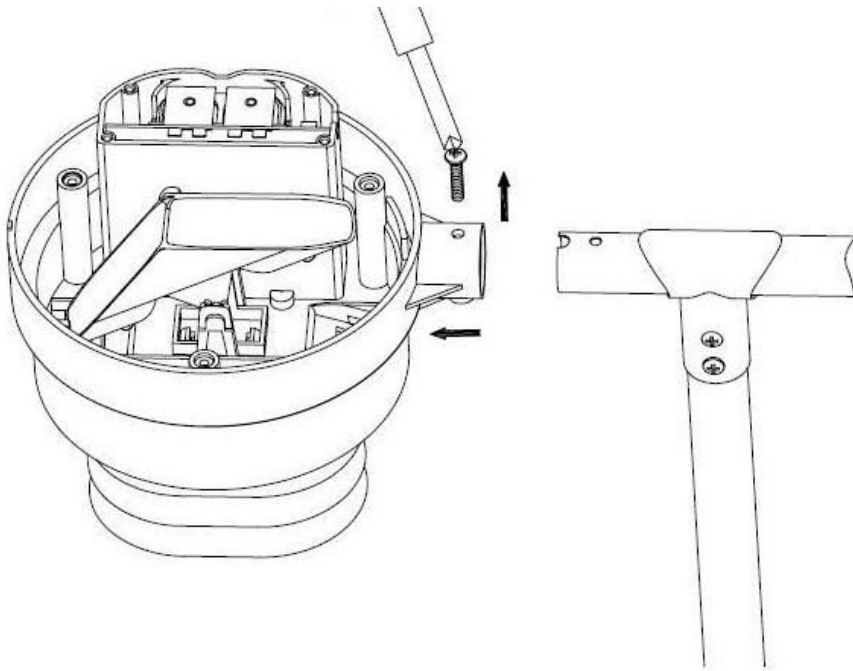

⑤

Replace wind sensor

Before replace the wind sensor, need to unplug the cable from rain sensor as illustration ④

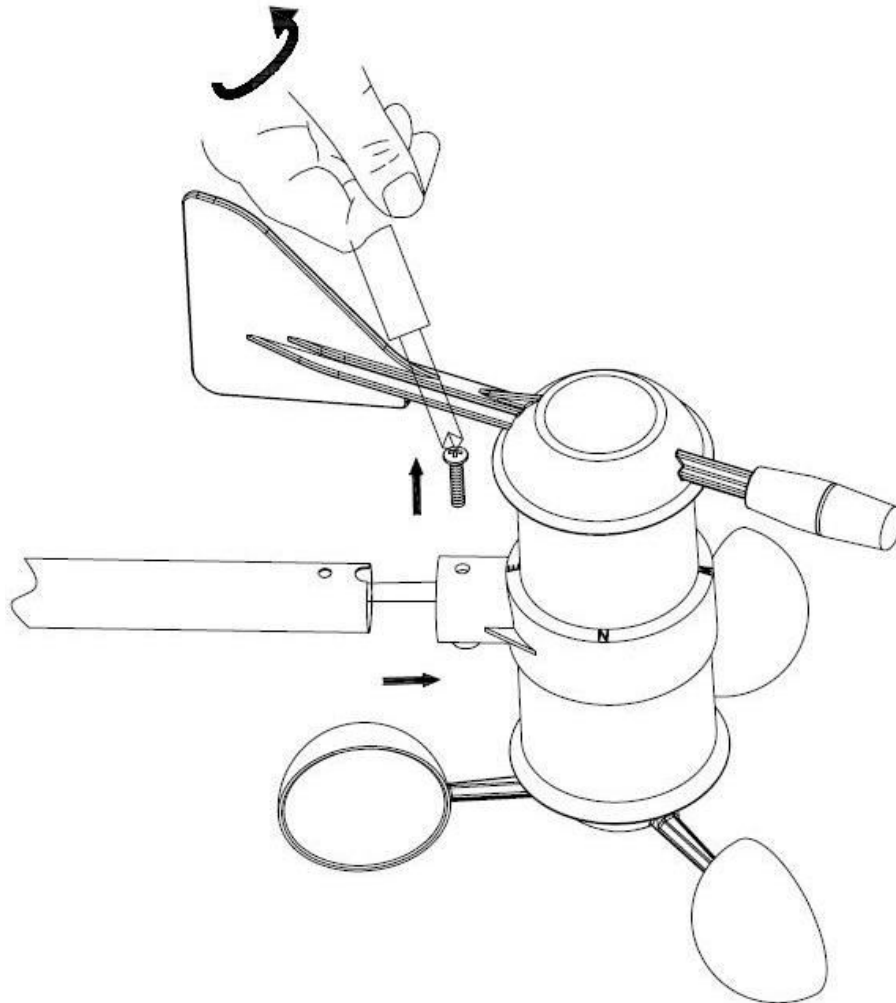

Notes on the return of batteries according to §12 BatterieVO: Batteries do not belong in the household waste. Please dispose of all batteries as required by law, disposal in domestic waste is expressly prohibited. Batteries and rechargeable batteries can be dispensed free of charge at municipal collection points or in the shops on the spot.

This manual may not be reproduced in any form without the written permission of the publisher, even in excerpts.

This manual may contain errors and misprints. However, the information in this manual is regularly reviewed and corrections made in the next issue. We accept no liability for technical errors or printing errors, and their consequences.

All trademarks and copyrights are acknowledged.

www.froggit.de



HS Group GmbH & Co. KG

Escherstr.31
50733 Koeln
Germany

Telefon 0221 / 367 48 05

E-Mail info@hs-group.de

Registergericht Amtsgericht Koeln HRA
26493

Komplementaer: HS Group
Verwaltungsgesellschaft mbH

Sitz Koeln

Registergericht Amtsgericht Koeln HRB
64734

Geschaeftsfuehrer: Peter Haefele, Carl
Schulte
UStId DE237971721
WEEE Reg. Nr. 66110125

declaration of conformity

Hereby we declare, HS-Group GmbH & Co.KG, Escherstr. 31, 50733 D-Cologne, that this product is in compliance with the essential requirements and other relevant provisions of Directive 1999/5 / EC. The declaration of conformity for this product can be found at: www.froggit.de or on request.