

DP70 Wireless Multi-channel Water Leak Detection Sensor

Contents

1. Introduction	3
2. Get Started.....	4
2.1 Parts List.....	4
3. Overview	5
3.1 Features	7
4. Setup Guide.....	8

4.1 Install batteries	8
5. Sensor Placement	14
6. Wi-Fi Configuration with gateway	15
6.1 Pair with Gateway	15
6.2 Wi-Fi Connection for the Gateway.	17
7. View Online Data with WS View	17
8. Set Email Alerts.....	19
9. Specification.....	22
.....	

1. Introduction

Thanks for purchasing this DP70 wireless multi-channel water leak detection sensor. The alarm will be triggered when water seepage is detected. The wireless signal can be received by the DP1500 Wi-Fi Gateway(sold separately) and the sensor data can be viewed on our WS View mobile application after the Wi-Fi configuration done.

To ensure the best product performance, please read this manual and retain it for future reference.

2. Get Started

2.1 Parts List

One Multi-channel Water Leak Sensor

One User Manual

3. Overview

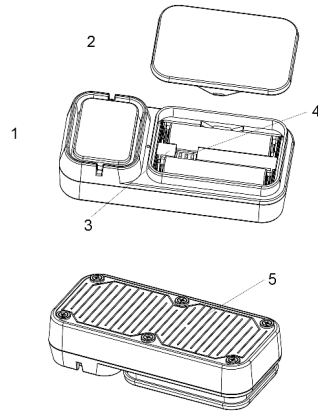

Figure 1: Multi-channel Water Leak Sensor

1	Buzzer (inside the device)
2.	Battery cover
3.	LED indicator
4.	Dip switches for multi-channel
5.	Sensor contact

Table : Sensor parts identification

3.1 Features

- Detects water seepage every 3 seconds.
- Emits loud alarm with 90dB once triggered.
- High or low sensor sensitivity selectable to meet different requirements.
- Works with DP1500 Wi-Fi gateway (sold separately) to complete the wifi configuration on WS View application.
- View live sensor data on the app once wifi configuration done.
- Email alerts available once the gateway device added successfully on our free Ecowitt Weather Server: <https://www.ecowitt.net>.
- Each DP1500 gateway supports to add up to

4 channels water leak sensors. Channel names can be edited both on the app and Ecowitt Weather Server.

- Battery power level display on the WS View App

4. Setup Guide

4.1 Install batteries

1.Remove the battery door on the back of the transmitter(s) by taking off the cover, as shown in **Fehler! Verweisquelle konnte nicht gefunden werden.**2 .

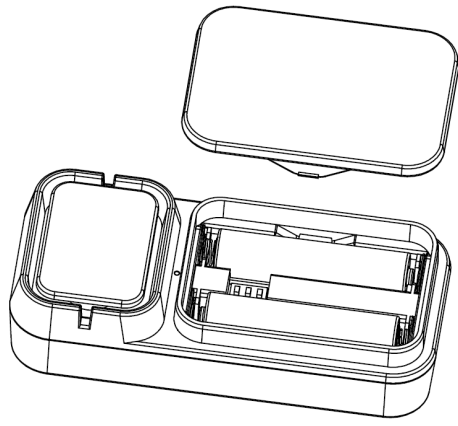

Figure 2: Battery installation

2. Before inserting the batteries, find the dip switches instruction above the battery compartment and set the sensor sensitivity level and channel number:

Sensitivity Level: To change the sensor sensitivity of detection (High or Low), change Dip Switch 3, as referenced in

Figure 3.

High sensitivity: The water leakage alarm will be triggered when the detected water leak capacitance value equals to or over 60PF and

be muted when the value equals to or lower 50PF.

Low sensitivity: The water leakage alarm will be triggered when the detected water leak capacitance value equals to or over 90PF and be muted when the value equals to or lower 80PF.

Channel Number: This device supports up to four sensors. To set each channel number, change Dip Switches 1 and 2 , as referenced in Figure 3.

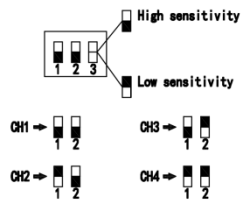
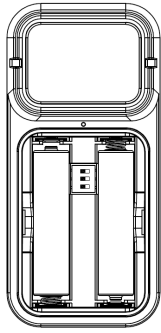



 Switch in down position.  Switch in up position.

Figure 3: Dip Switch diagram

3.Insert two 1.5V AAA batteries.

The LED indicator will turn on for four seconds and normally flash once every 60 seconds (the sensor transmission update period).

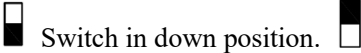
Note: If no LED light up or is lighted permanently, make sure the battery is inserted the correct way or a proper reset is happened. Do not install the batteries backwards. You can permanently damage the sensor.

4.Verify the correct channel number (CH) and sensor sensitivity level (High or Low) are

selected.

5. Close the battery door.

Repeat for the additional remote transmitters (sold separately), verifying each remote is on a different channel.

5. Sensor Placement

This device can be placed at multiple locations include under-the-sink cabinet in a kitchen or bathroom, near a water heater, a basement, a sump pump, a toilet, a washer, a humidifier, an AC unit, or ice-making refrigerator.

6. Wi-Fi Configuration with gateway

If you want to view the water leak sensor data on your mobile application and receive email alerts on our weather server, you need to pair this device with our DP1500 Wi-Fi Gateway (sold separately).

6.1 Pair with Gateway

If the DP1500 has been in operation, and you have never had any DP70 multi-channel water leak sensor(s) setup before, just power up the sensor(s) and DP1500 will pick the sensor data automatically.

If one DP70 sensor has been hooked on DP1500 before, and you have a new DP70 sensor to replace the old one, just power off the old sensor and power on the new sensor, the gateway will pick up the new sensor data automatically.

Then you may go to the Sensor ID page of the app (requires the Wi-Fi configuration done first) to Re-register or disable sensor(s) to ensure it's on the correct channel you.

6.2 Wi-Fi Connection for the Gateway

For this part, please refer to the manual of the DP1500 Wi-Fi gateway.

Any question, please contact the customer service.

7. View Online Data with WS View

When the Wi-Fi configuration is done, you may view leakage detection condition as well as the sensor battery level on WS view App at the live data page.

Live Data	
GW1000A-WIFI244D	
Indoor Temperature	Indoor Humidity
26.2 °C	56 %
Absolute Pressure	Relative Pressure
1012.2 hPa	1012.2 hPa
✔ CRH Leak	Normal
Firmware Version	
GW1000A_V1.5.5	

Device List	Live Data	Alerts
GW1000A-WIFI244D		
Indoor Temperature	Indoor Humidity	
26.7 °C	60 %	
Absolute Pressure	Relative Pressure	
1018.5 hPa	1019.5 hPa	
✔ CRH Leak	Normal	
GW1000A_V1.5.5		

Note: It requires your phone and the gateway using the same network to view your sensor data on the WS View app.

To remote monitor the sensor data, please upload the data to the free Ecovitt Weather Server: <https://www.ecovitt.net>.

Detailed operation instructions can be found on the DP1500 manual.

8. Set Email Alerts

Once your device added successfully on the

Ecovitt Weather server, you may set alerts for the water leak sensor(s) on the website to get email notifications.

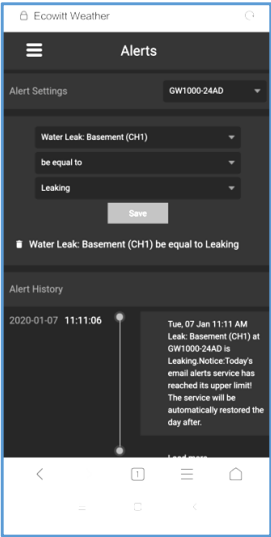

9.Specification

Power: 2X 1.5V AAA batteries(not included)

Sensor Size: 95x45x22.8mm

Frequency: 868 Mhz

Wireless transmitting range: 100M(300feet)

Alarm Decibel: 90dB

Sensor detecting interval: 3 seconds

Sensor reporting interval: 60 seconds

Waterproof level: IP44

Working temperature: 0~50°C(32~122°F)

Note: Once water seepage is detected, the device will emit 90dB alarm, and the ecowitt.net will push email alerts at the same time.

General safety instructions

Danger of asphyxiation:

Keep all packaging materials (plastic bags, rubber bands, etc.) away from children. There is a danger of suffocation!

Danger of burns:

Caution! Leaking / leaking battery acid can lead to burns! Avoid contact of battery acid with eyes, mucous membranes and skin. In case of contact, rinse the affected areas immediately with clear water and consult a doctor.

Risk of electric shock:

Children must not be unattended with the device, because the device contains electronic parts which are operated by means of a power source. The device may only be used as described in the instructions. If not, there is a risk of electric shock.

Danger of fire & explosion:

Use only recommended batteries. Never

short-circuit the unit or batteries. Never throw the device or batteries into a fire! Overheating and improper handling may result in short circuits which can cause fires and explosions.

Important:

If there is a defect, contact your dealer immediately. Never disassemble the device! The dealer will contact the service department. Never expose the device to water! Protect the device from vibrations. Only use recommended batteries. Never mix batteries - Always replace empty batteries with a complete set of full power batteries. If the unit is not powered for a longer period of time or is not in use, remove the batteries from the unit. The manufacturer accepts no liability for

incorrectly inserted batteries!



Notes on the return of batteries according to §12 BatterieVO: Batteries do not belong in the household waste. Please dispose of all batteries as required by law, disposal in domestic waste is expressly prohibited. Batteries and rechargeable batteries can be dispensed free of charge at municipal collection points or in the shops on the spot.

This manual may not be reproduced in any form without the written permission of the publisher, even in excerpts.

This manual may contain errors and misprints. However, the information in this manual is regularly reviewed and corrections made in the next issue. We accept no liability for technical errors or printing errors, and their consequences. All trademarks and copyrights are acknowledged.

www.froggit.de



HS Group GmbH & Co. KG
Escherstr.31
50733 Koeln
Germany

Telefon 0221 / 367 48 05

E-Mail info@hs-group.de

Registergericht Amtsgericht Koeln HRA 26493

Komplementaer: HS Group

Verwaltungsgesellschaft mbH

Sitz Koeln

Registergericht Amtsgericht Koeln HRB 64734

Geschaefsfuehrer: Peter Haefele, Carl Schulte

UStId DE237971721

WEEE Reg. Nr. 66110125

declaration of conformity

Hereby we declare, HS-Group GmbH & Co.KG, Escherstr. 31, 50733 D-Cologne, that this product is in compliance with the essential requirements and other relevant provisions of Directive 2014/53/EU.

The declaration of conformity for this product can be found at: www.froggit.de or on request.

