

DP300 WIRELESS SOLAR POWERED ANEMOMETER WITH UV&LIGHT SENSOR

Thank you for purchasing this Wireless Solar Powered Anemometer with UV & Light Sensor! This unit measures wind direction, wind speed, wind gust, UV & light . The data can be received by the froggit DP1500 Wi-Fi Gateway(sold separately) and can be viewed using the WS View mobile application (after Wi-Fi configuration on the gateway has been completed).

To ensure the best product performance, please read this manual and retain it for future reference.



Note: The stainless steel pole is not included.

1 Table of Contents

1 TABLE OF CONTENTS	2
2 UNPACKING	3
3 FEATURES	4
4 SET UP GUIDE	5
4.1 PRE INSTALLATION CHECKOUT	5
4.2 SITE SURVEY	5
4.3 SENSOR PACKAGE ASSEMBLY	6
4.3.2 <i>Install U-bolts and metal plate</i>	6
4.3.3 <i>Install wind vane</i>	8
4.3.4 <i>Install wind speed cups</i>	8
4.3.5 <i>Install Batteries in sensor package</i>	9
4.3.6 <i>Mount assembled outdoor sensor package</i>	10
4.3.7 <i>Reset Button and Transmitter LED</i>	12
5 SETUP GUIDE USING WI-FI GATEWAY	13
5.1 REPLACING AN EXISTING SENSOR UNIT	13
6 VIEW ONLINE DATA ON WS VIEW	14
7 SPECIFICATIONS.....	16

2 Unpacking

Open your outdoor sensor box and inspect that the contents are intact (nothing broken) and complete (nothing missing). Inside you should find the following:

QT	Item Description
1	Outdoor Sensor Body with built-in: Wind Speed Sensor/ Wind Direction Sensor, Light and UV sensor, Solar panel
1	Wind speed cups (to be attached to outdoor sensor body)
1	Wind vane (to be attached to outdoor sensor body)
2	U-Bolts for mounting on a pole
4	Threaded nuts for U-Bolts (M5 size)
1	Metal mounting plate to be used with U-Bolts
1	Wrench for M5 bolts
1	User manual (this manual)

Table 1: Package content

If components are missing from the package, or broken, please contact customer service to resolve the issue.

Note: Battery for the outdoor sensor package is **not included**. You will need 1 AA size batteries, alkaline or Lithium batteries (Lithium recommended for colder climates).

3 Features

- Measures wind direction, wind speed, wind gust, UV & light data.
- No display, need to work with the froggit DP1500 WIFI gateway to complete the WIFI configuration on our WS View App.
- After the WIFI configuration, the live wind, UV & light data can be viewed directly on the WS View App.
- Supports uploads to WU/WeatherCloud/WOW. The history graph of your WU station ID can be viewed on the WU Dashboard on the WS View App.
- Wind and UV & light sensor calibration functions available on the WS View App.

4 Set up Guide

4.1 Pre Installation Checkout

To complete assembly you will need a Philips screwdriver (size PH0) and a wrench (size M5; included in package).

Attention:

- Ensure battery is installed with correct polarity (+/-)
- Do not use rechargeable batteries
- If outdoor temperature may go below 32F or 0C for prolonged periods, Lithium based batteries are suggested over alkaline type batteries for the outdoor sensor array

4.2 Site Survey

Perform a site survey before installing the weather station. Consider the following:

- Ideally mounted at 32.8 feet (10 meters) above ground level.
- Try to make the anemometer the highest object around. 7 feet(2.76 meters) or more above the surrounding obstructions is best.
- Wireless Range. Radio communication between receiver and transmitter in an open field can reach a distance of up to 300 feet or 100 meter, providing there are no interfering obstacles such as buildings, trees, vehicles and high voltage lines. Wireless signals will not penetrate metal buildings. Under most conditions, the maximum wireless range is 100' or 30m.
- Radio Interference. Computers, radios, televisions and other sources can interfere with radio communications between the sensor array and console. Please take this into consideration when choosing console or mounting locations. Make sure your display console is at least five feet or 1.52 meter away from any electronic device to avoid interference.

4.3 Sensor Package Assembly

See Figure to locate and understand all the parts of the outdoor sensor package once fully assembled.

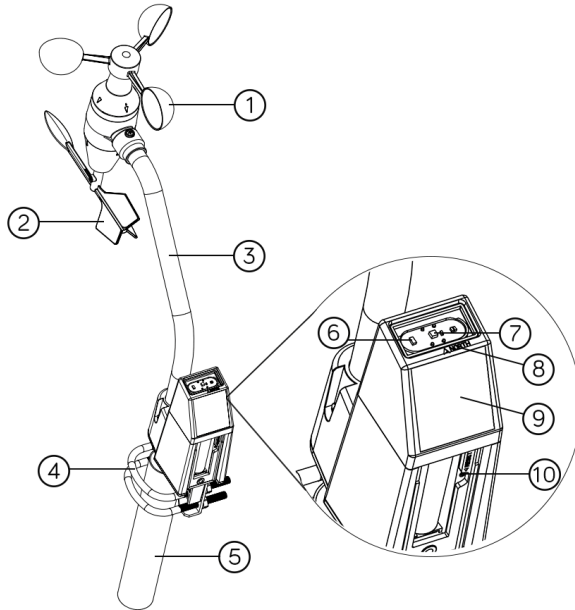

Figure 1: Sensor assembly components

1 Wind speed cups	6 LED (red) to indicate data transmission
2 Wind vane	7 Light sensor and UV sensor
3 Connection tube	8 NORTH arrow
4 U-Bolts	9 Solar panel
5 Mounting Pole(not included)	10 Reset button

Table 2: Sensor assembly detailed items

4.3.2 Install U-bolts and metal plate

Installation of the U-bolts, which are in turn used to mount the sensor package on a pole, requires installation of an included metal plate to receive the U-bolt ends. The metal plate, visible in Figure , has four holes through which the

ends of the two U-Bolts will fit. The plate itself is inserted in a groove on the right bottom of the unit. Note that one side of the plate has a straight edge (which goes into the groove), the other side is bent at a 90-degree angle and has a curved profile (which will end up “hugging” the mounting pole). Once the metal plate is inserted, remove nuts from the U-Bolts and insert both U-bolts through the respective holes of the metal plate as shown in Figure .

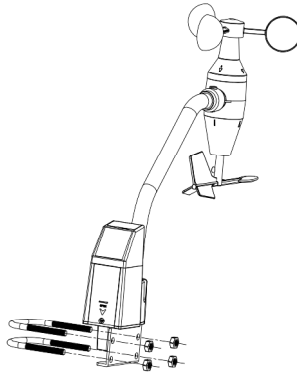

Figure 2: U-Bolt installation

Loosely screw on the nuts on the ends of the U-bolts. You will tighten these later during final mounting. Final assembly is shown in Figure .

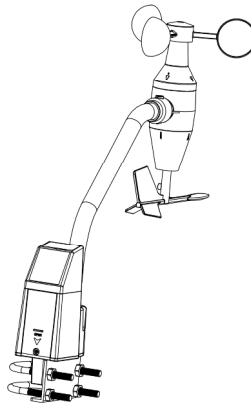

Figure 3: U-Bolts and nuts installed

The plate and U-Bolts are not yet needed at this stage but doing this now may help avoid damaging wind vane and wind speed cups later on. Handling of the sensor package with wind vane and speed cups installed to install these bolts is more difficult and more likely to lead to damage.

4.3.3 Install wind vane

Push the wind vane onto the shaft on the bottom side of the sensor package, until it goes no further, as shown on the left side in Figure . Next, tighten the set screw, with a Philips screwdriver (size PH0), as shown on the right side, until the wind vane cannot be removed from the axle. Make sure the wind vane can rotate freely. The wind vane’s movement has a small amount of friction, which is helpful in providing steady wind direction measurements.

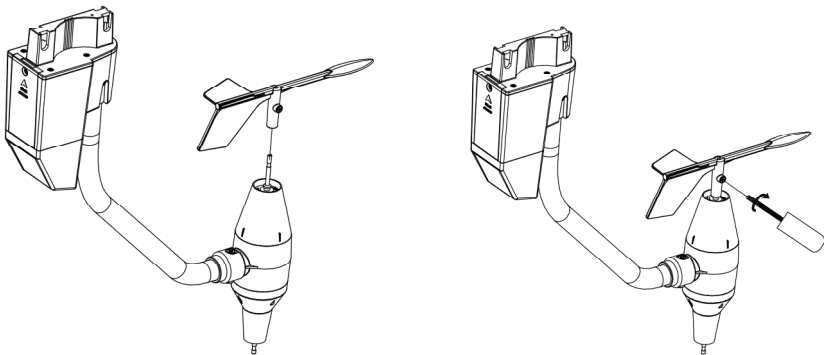

Figure 4: Wind vane installation diagram

4.3.4 Install wind speed cups

Push the wind speed cup assembly onto the shaft on the opposite side of the wind vane, as shown in Figure on the top side. Tighten the set screw, with a Philips screwdriver (size PH0), as shown on the right side. Make sure the cup assembly can rotate freely. There should be no noticeable friction when it is turning.

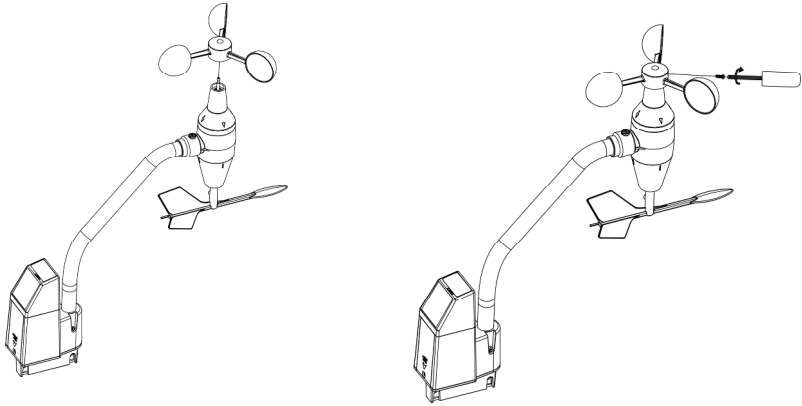

Figure 5: Wind speed cup installation diagram

4.3.5 Install Batteries in sensor package

Open the battery compartment with a screwdriver and insert 1 AA battery in the battery compartment. The LED indicator on the back of the sensor package (item 6) will turn on for 3 seconds and then flash once every 16.5 seconds indicating sensor data transmission. If you did not pay attention, you may have missed the initial indication. You can always remove the batteries and start over, but if you see the flash once every 16.5 seconds, everything should be OK.

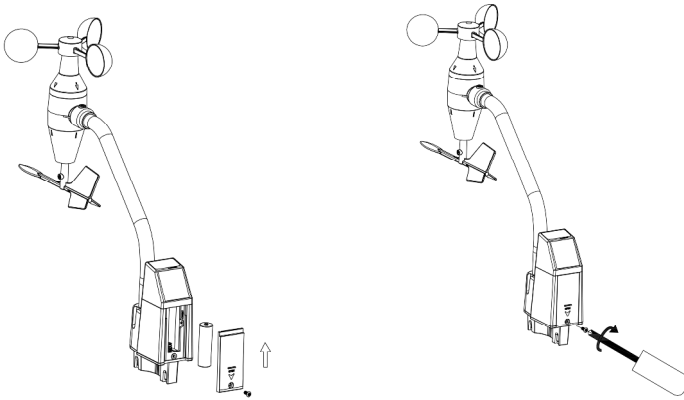

Figure 6: Battery installation diagram

Note: If LED does not light up or is on permanently, make sure the battery is inserted the correct way and inserted fully, starting over if necessary. Do not install the battery backwards as it may permanently damage the outdoor sensor.

Note: We recommend Lithium batteries for cold weather climates, but alkaline batteries are sufficient for most climates. Rechargeable batteries have lower voltages and should never be used.

4.3.6 Mount assembled outdoor sensor package

4.3.6.1 Before you mount

Before proceeding with the outdoor mounting detailed in this section, you may want to skip to setup instructions in section 5-6 and onwards first, while you keep the assembled outdoor sensor package nearby (although preferably not closer than 5 ft. or 1.53m from the froggit DP1500 gateway(sold separately)). This will make any troubleshooting and adjustments easier and avoids any distance or interference related issues from the setup.

After setup is complete and everything is working, return here for outdoor mounting. If issues show up after outdoor mounting they are almost certainly related to distance, obstacles etc.

4.3.6.2 Mounting

You can attach a pole to a permanent structure and then attach the sensor package to it (see Figure 7).

The U-Bolts will accommodate a pole diameter of 1-2 inches (pole not included).

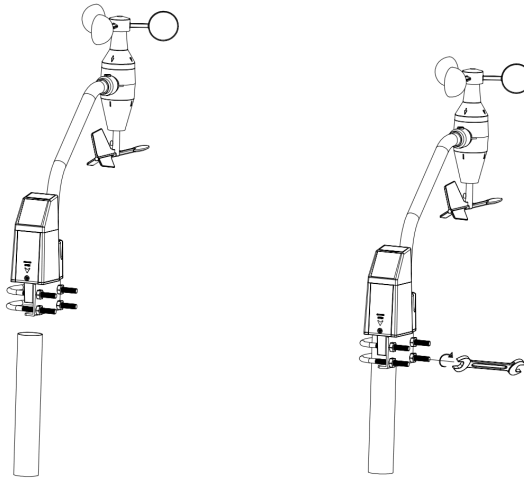

Figure 7: Sensor package mounting diagram

Make sure the mounting pole is vertical, or very close to it. Use a level if needed.

Finally, place the sensor package on top of the prepared mounting pipe. The U-Bolts should be loose enough to allow this but loosen the nuts as necessary. Once placed, hand tightens all four nuts, taking care to do so evenly. Do not use a wrench yet!

Now you will need to align the whole package in the proper direction by rotating it on top of the mounting pipe as needed. Locate the arrow labeled “NORTH” that you will find on top of the transparent cover on the sensor package (Item 8). You must rotate the whole sensor package until this arrow points due north. To achieve proper alignment, it is helpful to use a compass (many cell phones have a compass application). Once rotated in the correct

orientation, lightly tighten the bolts a little more (use a wrench) to prevent further rotation.

Note: The orientation to NORTH is necessary for two reasons. The most important one is to position the solar panel and light sensor in the most advantageous position for recording solar radiation and charging internal capacitors. Secondly it causes a zero reading for wind direction to correspond to due NORTH, as is customary.

Make sure the sensor package is installed vertically. If it is not, wind direction and speed readings may not operate correctly or accurately. Adjust the mounting pipe as necessary.

Make sure you check, and correct if necessary, the north orientation as the final installation step, and now tighten the bolts with a wrench. Do not over tighten, but make sure strong wind and/or rain cannot move the sensor package.

4.3.7 Reset Button and Transmitter LED

In the event the sensor package is not transmitting, reset the sensor package.

Using a bent-open paperclip, press and hold the **RESET BUTTON** (item 10) to affect a reset: the LED turns on while the RESET button is depressed, and you can now let go. The LED should then resume as normal, flashing approximately once every 16.5 seconds.

5 Setup Guide using Wi-Fi Gateway

If you wish to view the sensor data on your mobile device, you need to pair this sensor device with the **froggit DP1500** Wi-Fi Gateway (sold separately), or another compatible device.

Before you can use the mobile application to connect to the Wi-Fi Gateway, it must be configured on your Wi-Fi network. Instructions may be found in the gateway manual.

5.1 Replacing an existing sensor unit

If this sensor is a replacement for a previous unit, ensure the previous unit is powered down. Also unplug the DP1500 Wi-Fi Gateway from the USB connection, wait a few seconds, and re-connect the gateway to USB power.

Now simply insert the battery to power up the sensor unit, and the Wi-Fi Gateway will quickly pick up the sensor information. It is best to always do this in the vicinity of the Wi-Fi Gateway to rule out distance or signal interference effects, and to move the unit to the final location once correct configuration is confirmed.

6 View Online Data on WS View

After correct Wi-Fi configuration on the gateway, you can view all sensor data on the “Live Data” screen of the WS View application

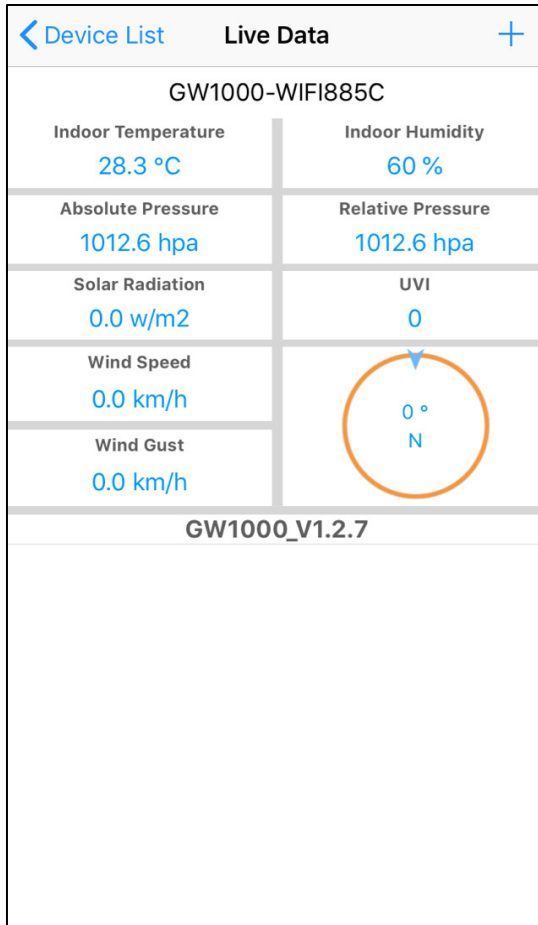

Figure 8: WS View Live Data Screen

Note:

1. This sensor data supports uploads to WU/WeatherCloud/WOW. The sensor history graph of your WU station ID can be viewed on the WS View App.
2. You can also choose to upload the data to the www.ecowitt.net weather server, then you can view or download the history graph and records on the website.

7 Specifications

Note: Out of range values will be displayed using “---” on WS VIEW:

Outdoor sensor	Specification
Transmission distance in open field	100 m (330 ft.)
RF Frequency	433 / 868 / 915 MHz depending on location United States: 915 MHz
Wind speed range	0 – 50 m/s (0 ~ 100 mph)
Wind speed accuracy	± 1 m/s (speed < 5 m/s) ± 10% (speed ≥ 5 m/s), or ± 0.1 mph (speed < 11 mph) ± 10% (speed ≥ 11 mph)
UV-Index range	0 - 15
Light range	0 – 120 kLux
Light accuracy	± 15%
Sensor reporting interval	16.5 seconds

Table 3: Outdoor sensor specification

Power	Specification
Outdoor sensor	Solar panel (built-in): 6.5V/4mA
Outdoor sensor (backup)	1 x AA 1.5V LR6 Alkaline (not included), or 1 x AA 1.5V Lithium battery (not included)

Table 4: Power specification

The primary power source for the outdoor sensor is the solar panel. When available solar power (light over recent period) is insufficient, the batteries will be used. In outdoor climates that frequently have sustained temperatures below 0°C (or 32°F) the use of Lithium batteries is strongly suggested as these are performing better than Alkaline batteries under such circumstances.

General safety instructions

Danger of asphyxiation:

Keep all packaging materials (plastic bags, rubber bands, etc.) away from children.

There is a danger of suffocation!

Danger of burns:

Caution! Leaking / leaking battery acid can lead to burns! Avoid contact of battery acid with eyes, mucous membranes and skin. In case of contact, rinse the affected areas immediately with clear water and consult a doctor.

Risk of electric shock:

Children must not be unattended with the device, because the device contains electronic parts which are operated by means of a power source. The device may only be used as described in the instructions. If not, there is a risk of electric shock.

Danger of fire & explosion:

Use only recommended batteries. Never short-circuit the unit or batteries. Never throw the device or batteries into a fire! Overheating and improper handling may result in short circuits which can cause fires and explosions.

Important:

If there is a defect, contact your dealer immediately. Never disassemble the device!

The dealer will contact the service department. Never expose the device to water!

Protect the device from vibrations. Only use recommended batteries. Never mix

batteries - Always replace empty batteries with a complete set of full power batteries. If

the unit is not powered for a longer period of time or is not in use, remove the batteries from the unit. The manufacturer accepts no liability for incorrectly inserted batteries!



Notes on the return of batteries according to §12 BatterieVO: Batteries do not belong in the household waste. Please dispose of all batteries as required by law, disposal in domestic waste is expressly prohibited. Batteries and rechargeable batteries can be dispensed free of charge at municipal collection points or in the shops on the spot.

This manual may not be reproduced in any form without the written permission of the publisher, even in excerpts.

This manual may contain errors and misprints. However, the information in this manual is regularly reviewed and corrections made in the next issue. We accept no liability for technical errors or printing errors, and their consequences.

All trademarks and copyrights are acknowledged.

www.froggit.de



HS Group GmbH & Co. KG

Escherstr.31

50733 Koeln

Germany

declaration of conformity

Hereby we declare, HS-Group GmbH & Co.KG, Escherstr. 31, 50733 D-Cologne, that this product is in compliance with the essential requirements and other relevant provisions of Directive 2014/53/EU.

The declaration of conformity for this product can be found at: www.froggit.de or on request.